

 **CORGI**

artiglio 500



SMONTAGOMME AUTOMATICO 32" CON TECNOLOGIA "LEVA LA LEVA" DI 2^A GENERAZIONE

Ancora più performante, ancora più geniale



32" AUTOMATIC TYRE CHANGER WITH 2ND GENERATION "LEVA LA LEVA" (WITHOUT LEVER) TECHNOLOGY

Even more performing, even more ingenious





Nuovo smontagomme automatico con tecnologia **“leva la leva” di 2^a generazione** per ruote vetture, SUV e veicoli commerciali **fino a 32”**. Numerose novità tecniche: dispositivo di stallonatura dinamica con **doppio disco stallonatore**, gruppo testata di nuova concezione, bloccaggio ruota a platorello più performante, struttura rinforzata, grande cura dell’ergonomia e della fruibilità dei comandi. Tutto questo significa maggiore velocità operativa senza rischi per l’operatore e i cerchi, anche durante le fasi più impegnative, grande semplicità d’uso e universalità, per un’attrezzatura sfruttabile al 100% in tutte le sue peculiarità.

*New automatic tyre changer with 2nd generation **“Leva la leva” (Without lever) technology** for vehicle, SUV and commercial vehicles wheels **up to 32”**. Many technical innovations: dynamic bead breaking device with a **dual bead breaker disc**, newly designed head group, more performing wheel support plate clamping, reinforced structure, great attention to ergonomics and control availability. All of this means a faster operating speed without risks to the operator and the rims, even during the most critical phases, great simplicity of use and universality, for equipment whose features can be used 100%.*

1

CONSOLLE - CONSOLES

Intuitiva e completa - Console comandi multifunzione che racchiude tutti i comandi di lavoro. Ideale per la stallonatura dinamica e per la possibilità di fare il match mounting tra pneumatico e cerchio, grazie ai due dischi a doppio comando.

***Intuitive and complete** - The multifunctional control console contains all the operating controls. Ideal for dynamic bead breaking and for rim and tyre match mounting, thanks to the two dual control discs.*

2

DOPPIO STALLONATORE A PENETRAZIONE CONTROLLATA - DYNAMIC BEAD BREAKING DEVICE WITH CONTROLLED PENETRATION

Dispositivo di stallonatura dinamica con doppio disco stallonatore speculare. Il posizionamento radiale dei dischi è facilitato da un automatismo in grado di evitare ogni posizionamento manuale dell'operatore.

Penetrazione controllata (Patented) Precisione, rapidità e ripetitività sono garantiti dal sistema di stallonatura brevettato e dalla perfetta specularità tra i due dischi.



Watch the Video

Dynamic bead breaking device with dual specular bead breaker disc.

The radial positioning of the discs is made easier by an automatism that is able to prevent any manual positioning by the operator.

Controlled penetration (Patented) Precision, rapidity and repeatability are guaranteed by the patented bead breaking system and by the perfectly synchronised and symmetrical motions of the two discs.



PROCEDURA RAPIDA DI SMONTAGGIO SECONDO TALLONE - RAPID SECOND BEAD DEMOUNTING PROCEDURE



Procedura rapida smontaggio secondo tallone resa possibile da **movimento disco brevettato**, particolarmente indicata con fianchi duri.

Quick second bead demounting procedure made possible by a patented disc movement, particularly useful with stiff sidewalls.

3

MOTORIZZAZIONE CON SISTEMA MOTOINVERTER - MOTOINVERTER DRIVE SYSTEM



LA GIUSTA COPPIA
ALLA GIUSTA VELOCITÀ (7-18 RPM).

THE RIGHT TORQUE
AT THE RIGHT SPEED (7 - 18 RPM).





4 SOLLEVATORE RUOTA - WHEEL LIFTER

Senza fatica - Fornito di serie, il sollevatore consente di posizionare sull'autocentrante ogni tipo di ruota senza sforzo.

Effortless operation - A wheel lifter is fitted as standard, for effortlessly placing wheels of any type onto the turntable.



5

GRUPPO TESTATA - HEAD UNIT

La procedura di smontaggio mantiene invariati i movimenti di lavoro **eliminando in maniera definitiva lo sforzo fisico** dell'operatore grazie alla tecnologia **Leva la leva** applicata alla torretta (**Patented**).

La procedura di montaggio mantiene invariati i movimenti, la **praticità**, e la **velocità d'esecuzione**.

*The demounting procedure uses the same working movements but absolutely **no effort is required** from the operator thanks to the "Leva la leva" (Without lever) technology incorporated in the head (**Patented**).*

The mounting procedure doesn't change: it is just as quick and convenient as before.



Watch the Video

**Procedura di smontaggio del tallone superiore - Top bead demounting procedure**

6

BLOCCAGGIO RUOTA SICURO E UNIVERSALE - SAFE AND UNIVERSAL WHEEL CLAMPING

L'autocentrante a platorello consente un **rapido bloccaggio**, permettendo inoltre la stallonatura di entrambi i fianchi senza bisogno di girare la ruota.

*The axial mounting turntable ensures **rapid clamping** while permitting bead breaking on both sides without having to turn the wheel itself.*



7 **PREMITALLONE (A RICHIESTA)** *BEAD DEPRESSOR (OPTIONAL)*

- Premitalлоне ad altezza di lavoro regolabile
- La forma del pressore è ideale per pneumatici RFT
- *Bead depressor with adjustable working height*
- *Depressor shape ideal for RFT tyres*

“ **RUN FLAT - NO PROBLEM!** ”



ERGONOMIA - ERGONOMICS

Altezza di lavoro della macchina studiata per ottenere una **perfetta ergonomia nei movimenti** con tutti i tipi di ruote: Ideale per tutti gli operatori.
*Machine working height designed to obtain **perfect ergonomic movement** with all wheel types: Ideal for all operators.*



*altezza costante
*constant height

Tutti i comandi che controllano i movimenti della macchina si trovano in posizioni ergonomiche all'operatore

All machine movement controls are conveniently to hand for the operator

*eccezione per cerchi a canale rovescio.
*except for reverse rims.

DATI TECNICI - TECHNICAL DATA

range dimensioni ruota	wheel dimension range	
diametro cerchio	rim diameter	da 12" a 32" - from 12" to 32"
diametro max pneumatico	maximum tyre diameter	1200 mm (47") - 1200 mm (47")
larghezza massima pneumatico	maximum tyre width	15" (dal piano appoggio ruota) - (from wheel supporting base)
pneumatici trattabili	tyre types processed	convenzionali, low profile e Run Flat - conventional, Low Profile and Run Flat
autocentrante	turntable	
bloccaggio	clamping	meccanico-manuale - mechanical-manual
motorizzazione	drive system	motoinverter 2 velocità - 2-speed motoinverter
coppia di rotazione	rotation torque	1100 Nm
velocità di rotazione	rotation speed	7-18 rpm
stallonatore	bead breaker	
campo massimo di stallonatura	maximum bead breaking range	670 mm
corsa stallonatore	bead breaker stroke	540 mm
forza stallonatore	bead breaker force	7600 N
carico/scarico ruota	wheel loading/unloading	
azionamento	operation	pneumatico - pneumatic
peso max ruota	max wheel weight	85 Kg
alimentazione	power supply	
elettrica 1Ph	electric 1Ph	230V-0,98 kW 50Hz/60 Hz
elettrica 1Ph (alternativa)	electric 1Ph (alternative)	110V-0,98 kW 50Hz/60 Hz
pneumatica di esercizio	pneumatic operating pressure	8 bar (minima) - 8 bar (minimum)
peso	weight	380 kg (con sollevatore) - 380 kg (with wheel lifter)

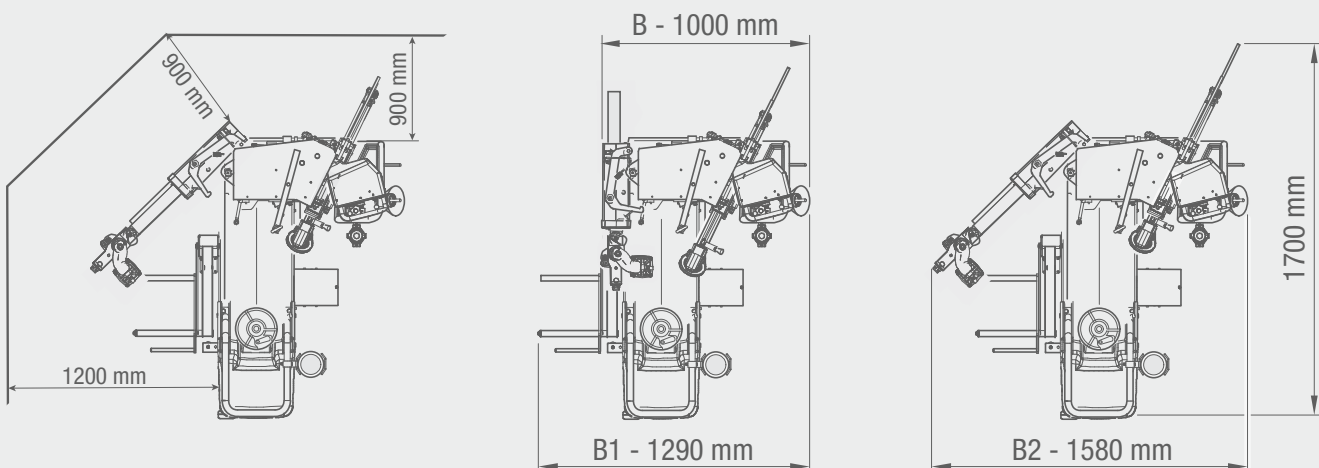
DIMENSIONI DI INGOMBRO - OVERALL DIMENSIONS

ACCESSORI IN DOTAZIONE - STANDARD ACCESSORIES



ACCESSORI CONSIGLIATI - RECOMMENDED ACCESSORIES

- A** **8-11100111**
Kit TI - Sistema gonfiaggio rapido
TI system Kit
- B** **8-11100087**
Flangia universale per cerchi speciali
(per versione con bloccaggio manuale)
*Universal flange for special rims
(for manual wheel clamping version)*
- C** **8-11100338**
Kit per ruote pax system
Pax system wheel kit
- D** **8-11100237**
Maniglia di bloccaggio AUTOLOCK II
AUTOLOCK II automatic clamping
- E** **8-11100039**
Flangia universale per cerchi
a canale rovescio
Reverse wheel flange
- F** **8-11100120**
Morsetto basculante
Sliding bead pressing clamp
- G** **8-11100221**
Kit premitallone pneumatico
Pneumatic bead pressing tool
- H** **6015001300**
TPM-02 Dispositivo portatile
per il controllo dei sensori TPMS
*TPM-02 Device for checking operation
of TPMS sensors*
- I** **8-11100086**
Kit cerchi furgone
Pick-up rim kit

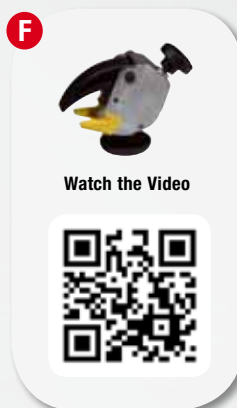

Per maggiori informazioni consultare il catalogo accessori completo
For further information, consult the complete accessories catalogue.

Watch the Video ▶

